

LOC	DIST	REVISIONS					
		P	LTR	DESCRIPTION	DATE	DWN	APVD
J	-	B		REVISED (ECR-06-024642)	17OCT06	S.L	S.Y

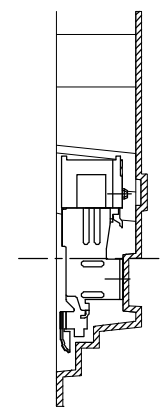

B-B SCALE 1:1

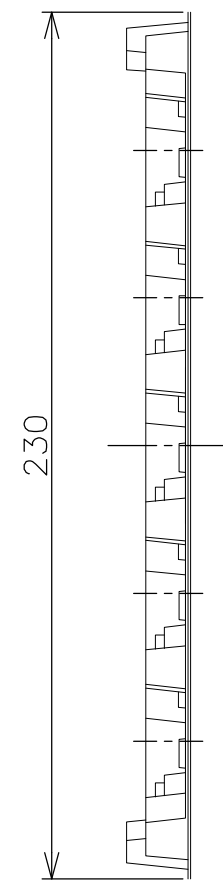
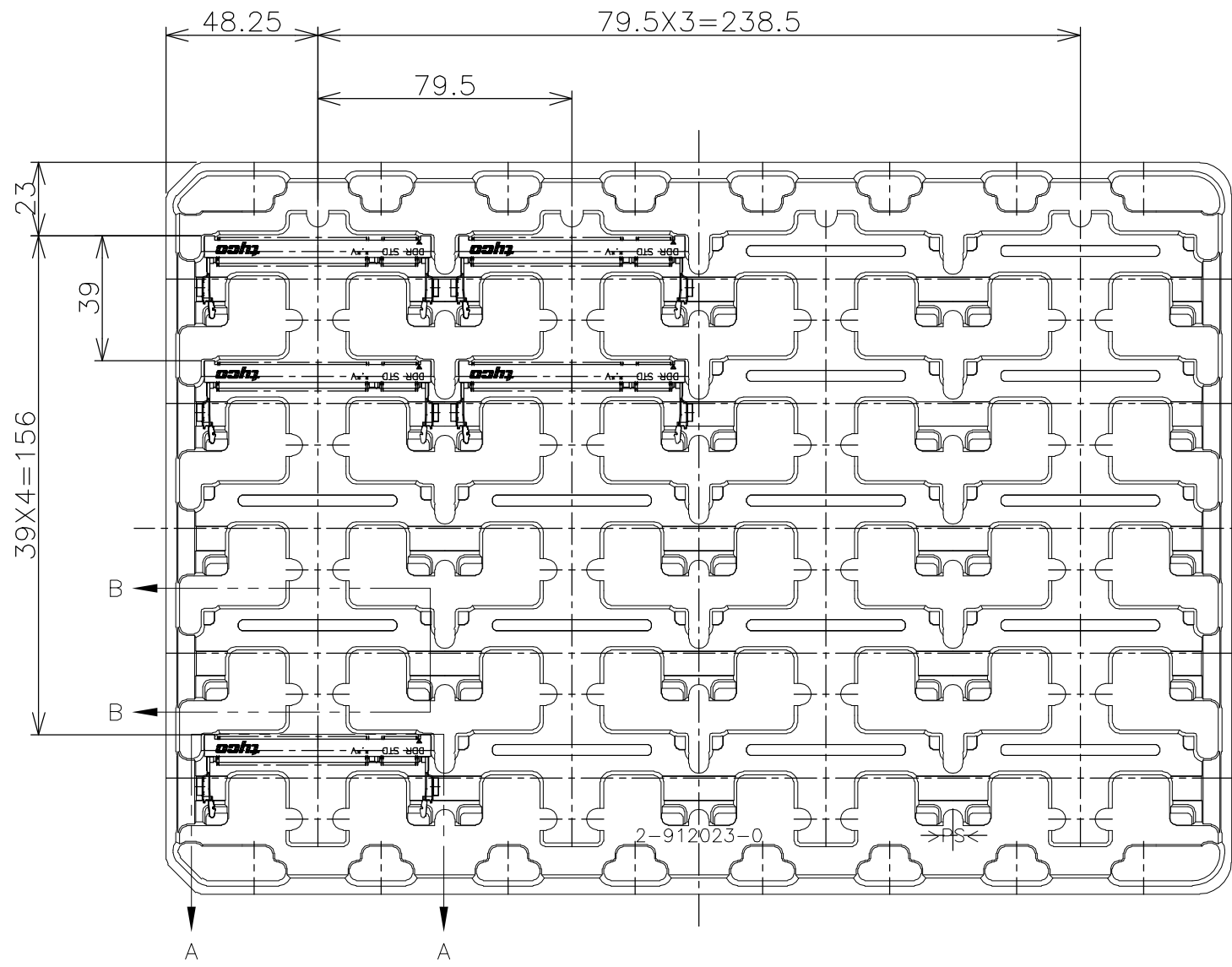
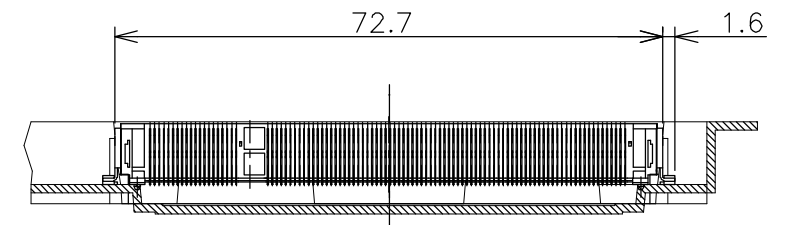

A-A SCALE 1:1 (180DEG. ROTATE)

- (APPLIED TO SHEET 1)
 1. THE DIRECTION OF EACH CONNECTOR ON A TRAY IS REFERRED TO THIS DRAWING.
 2. GENERAL TOLERANCE: ±0.5

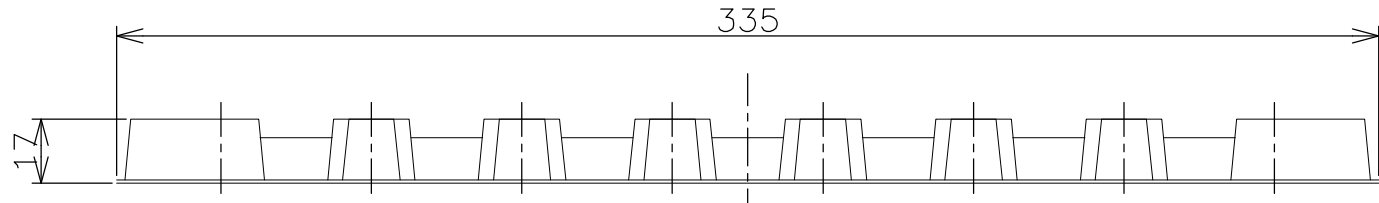

1.8V (DDR2)	20EA/TRAY	1747407-4
2.5V (DDR1)	20EA/TRAY	1747407-1
POWER SUPPLY(TYPE)	QTY	P/N

THIS DRAWING IS A CONTROLLED DOCUMENT.		DWN	LEO ZHOU	18JAN05	 Tyco Electronics AMP K.K. Kawasaki, Japan							
DIMENSIONS: MM		CHK	T.KAWAMAE	18JAN05								
TOLERANCES UNLESS OTHERWISE SPECIFIED:		APVD	I.ENOMOTO	18JAN05								
0 PLC ± 1 PLC ± 2 PLC ± 3 PLC ± 4 PLC ± ANGLES ± MATERIAL FINISH		PRODUCT SPEC	108-5701		NAME	DDR1 & DDR2 SODIMM SOCKET 0.6mm PITCH 200POS 8mm HEIGHT STANDARD TYPE (LATCH DIRECT SOLDERING TYPE)						
GENERAL TOLERANCE 0~10 : ±0.2 10~30 : ±0.25 30~100 : ±0.3 ANGLES : ±3°		APPLICATION SPEC	WEIGHT		SIZE	A3	CAGE CODE	00779	DRAWING NO	1747407	RESTRICTED TO	
		CUSTOMER DRAWING			SCALE	1:2	SHEET	1	OF	4	REV	B

THIS DRAWING IS UNPUBLISHED. RELEASED FOR PUBLICATION NOV. 2002.
 © COPYRIGHT 2002 BY TYCO ELECTRONICS CORPORATION. ALL RIGHTS RESERVED.

LOC	DIST	REVISIONS					
		P	LTR	DESCRIPTION	DATE	DWN	APVD
J	-	-	-	SEE SHEET 1	-	-	-

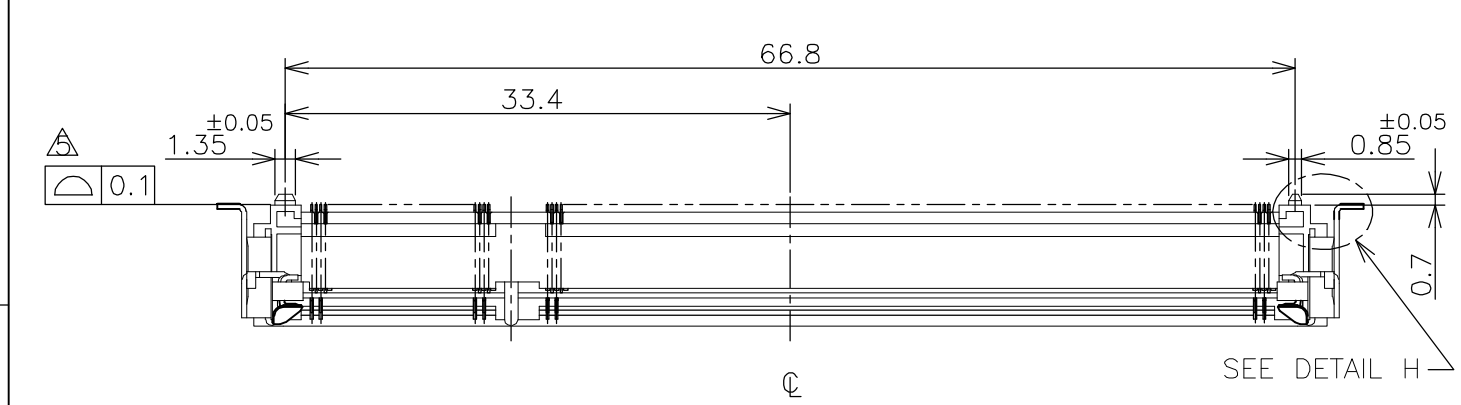

HOW TO MATE AND UNMATE

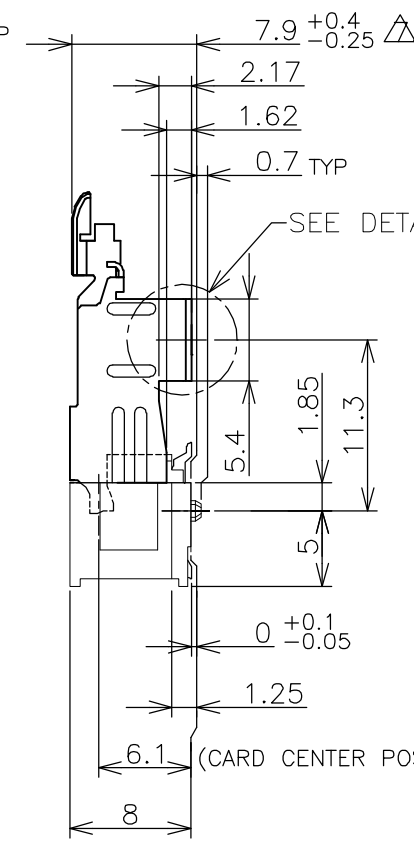
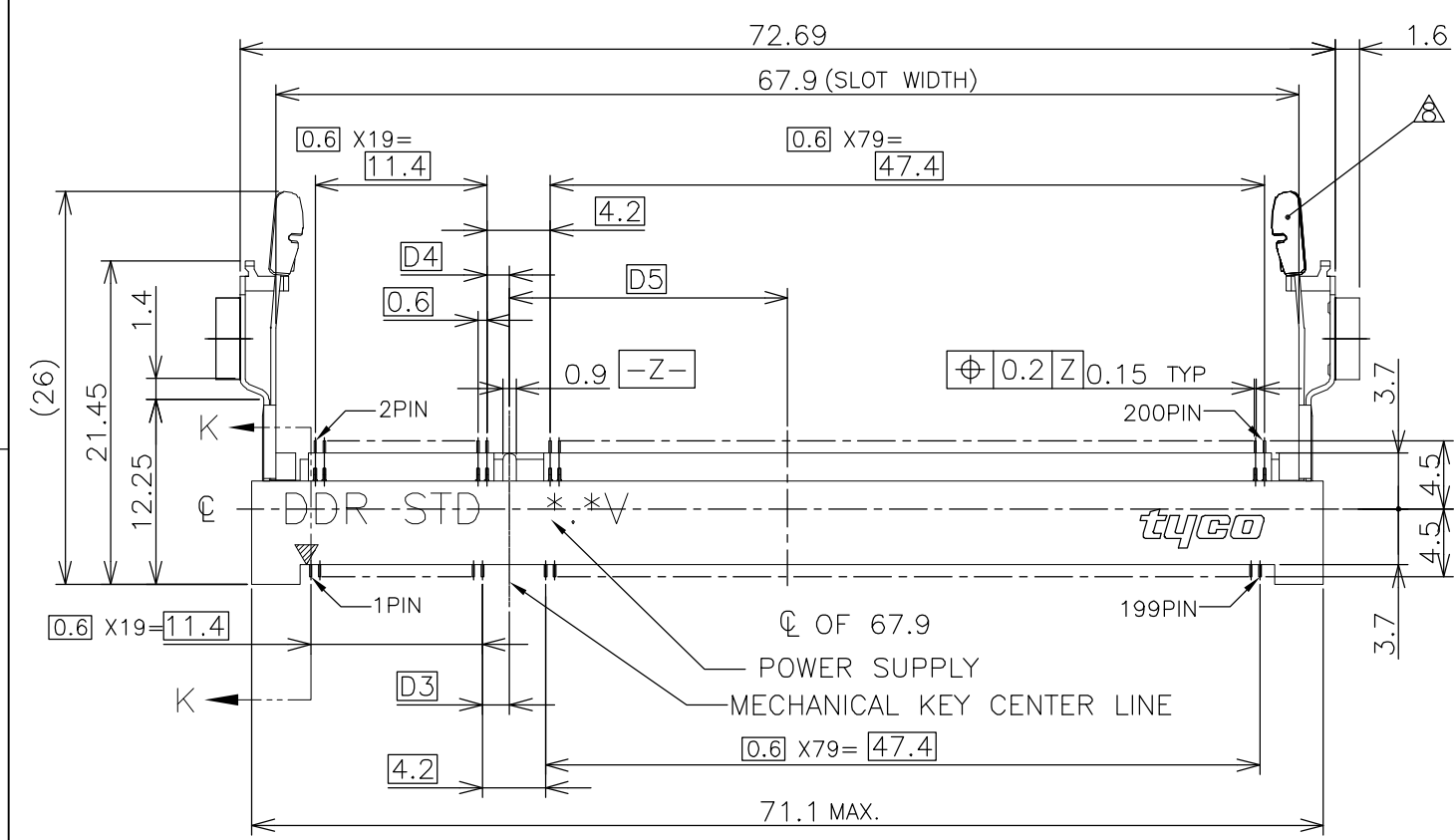
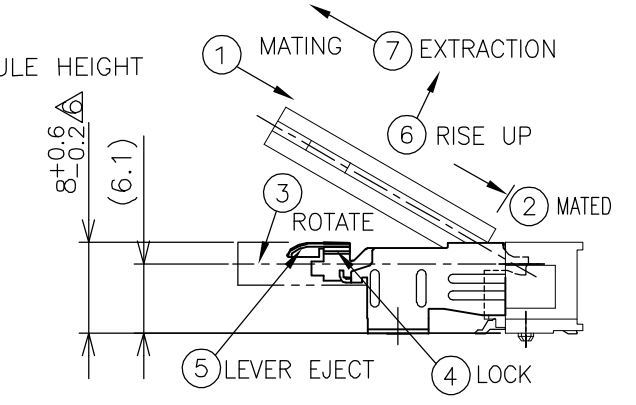
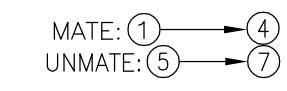

(APPLIED TO SHEET 2-3)

- MATERIAL ; HOUSING:HIGH TEMPERATURE THERMO PLASTIC UL94V-0, COLOR : BLACK
CONTACT : COPPER ALLOY
LOCK LEVER : STAINLESS STEEL
 - FINISH ; CONTACT : Au PL. IN CONTACT AREA AND SOLDERING AREA ON NICKEL UNDER PL.
SOLDERING AREA(LOCK LEVER) : TIN PL.
- MECHANICAL KEY POSITION OF CONNECTOR SEE TABLE.
 - TOLERANCES NON-CUMMURATIVE.
 - COPLANARITY: 0.1MAX
 - THE FLOATING VALUE BY SOLDERING IS NOT INCLUDED.
 - NOT MATING CONDITION.
 - THIS PART IS NOT THE TYPE WHICH PREVENTS HALF MATING.
 - IF THE MODULE DOESN'T INSERT AND LOCK IN THE LATCH SMOOTHLY, OPEN WIDE BOTH LATCHES BY MANUAL. AND THE MODULE MUST BE INSERTED AND LOCKED IN THE LATCH.

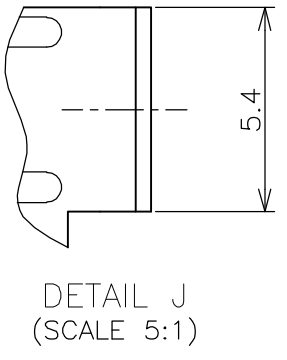
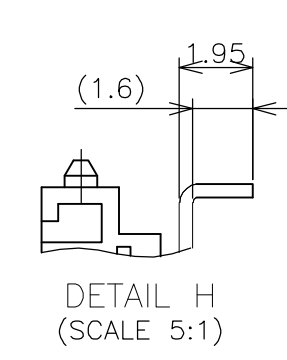
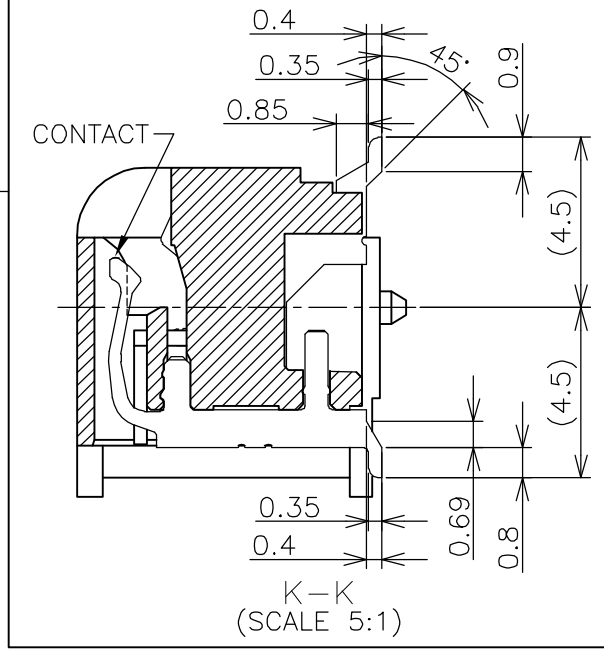

AVAILABLE	1.8V (DDR2)	17.55	2.4	2.7	200	1747407-4
AVAILABLE	2.5V (DDR1)	18.45	1.5	1.8	200	1747407-1
TOOLING STATUS	POWER SUPPLY (TYPE)	D5	D4	D3	POS	PART NO.

THIS DRAWING IS A CONTROLLED DOCUMENT.		DWN		Tyco Electronics AMP K.K. Kawasaki, Japan	
DIMENSIONS: MM		CHK			
TOLERANCES UNLESS OTHERWISE SPECIFIED:		APVD		NAME	
0 PLC ±		PRODUCT SPEC		DDR1 & DDR2 SODIMM SOCKET 0.6mm PITCH	
1 PLC ±		APPLICATION SPEC		200POS 8mm HEIGHT STANDARD TYPE	
2 PLC ±		WEIGHT		(LATCH DIRECT SOLDERING TYPE)	
3 PLC ±		SIZE		CAGE CODE	
4 PLC ±		DRAWING NO		RESTRICTED TO	
ANGLES ±		A3		00779	
FINISH		C-1747407			
MATERIAL		CUSTOMER DRAWING		SCALE 2:1	
				SHEET 2 OF 4	
				REV B	

LOC	DIST	REVISIONS			
P	LTR	DESCRIPTION	DATE	DWN	APVD
J	-	SEE SHEET 1	-	-	-

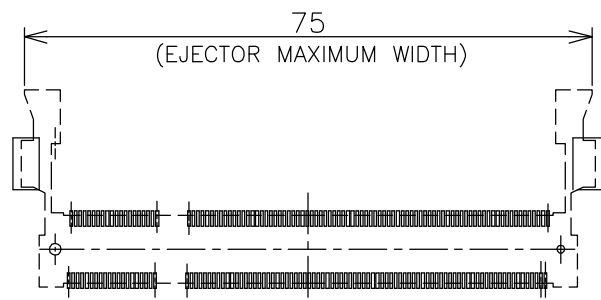

REAL SIZE (SCALE 1:1)

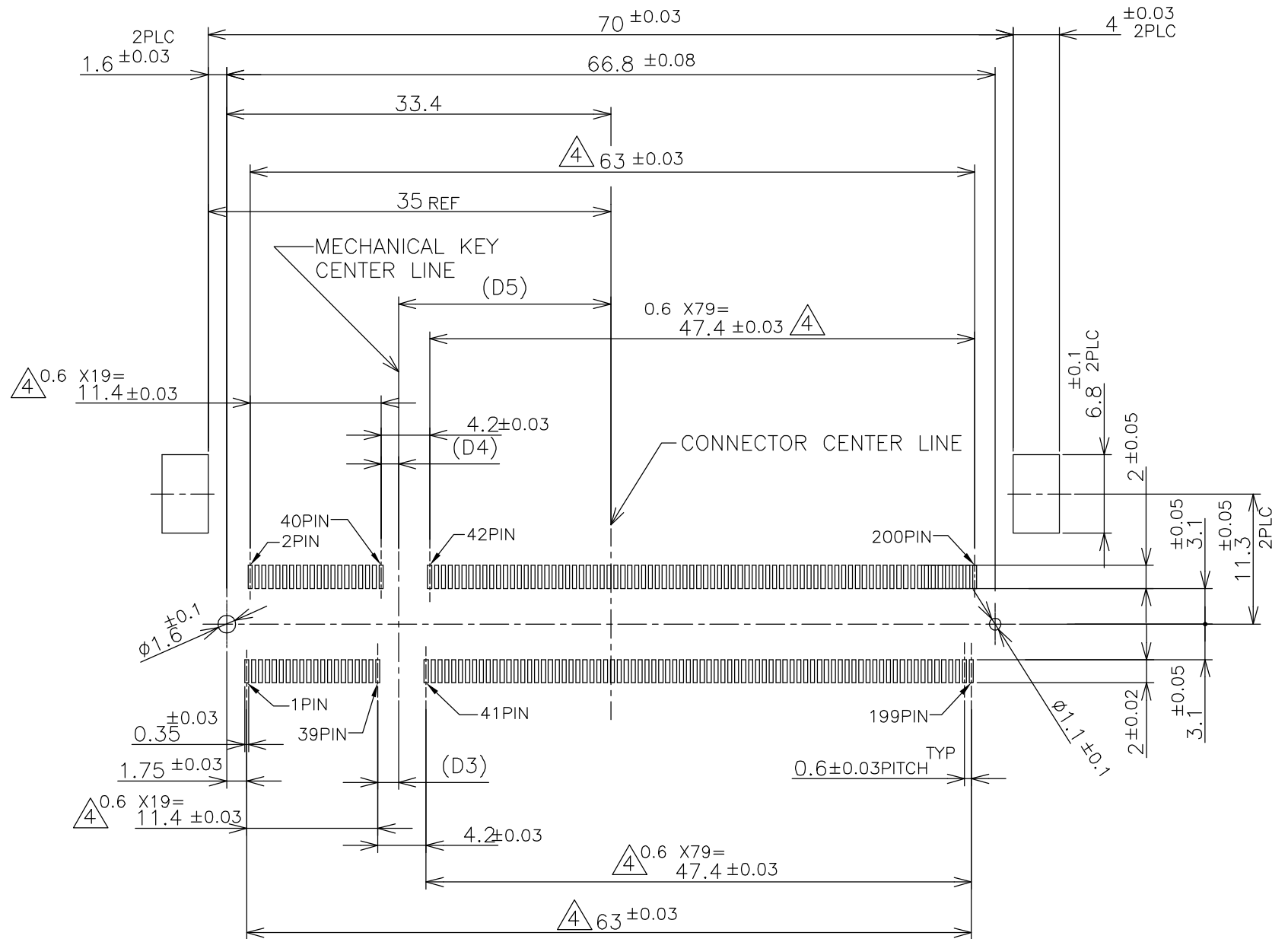

REFERENCE P.C.BOARD PATTERN LAYOUT FOR DUAL USE (CONNECTOR MOUNTING SIDE)

THIS DRAWING IS A CONTROLLED DOCUMENT.		DWN	Tyco Electronics AMP K.K. Kawasaki, Japan		
DIMENSIONS: MM		CHK			
TOLERANCES UNLESS OTHERWISE SPECIFIED:		APVD	NAME		
0 PLC ±		PRODUCT SPEC	DDR1 & DDR2 SODIMM SOCKET 0.6mm PITCH		
1 PLC ±		APPLICATION SPEC	200POS 8mm HEIGHT STANDARD TYPE		
2 PLC ±		WEIGHT	SIZE	CAGE CODE	DRAWING NO
3 PLC ±			A3	00779	C-1747407
4 PLC ±		CUSTOMER DRAWING		SCALE	SHEET
ANGLES ±				2:1	3 OF 4
FINISH				REV	B

THIS DRAWING IS UNPUBLISHED. RELEASED FOR PUBLICATION NOV. 2002.
 © COPYRIGHT 2002 BY TYCO ELECTRONICS CORPORATION. ALL RIGHTS RESERVED.

LOC	DIST	REVISIONS			
P	LTR	DESCRIPTION	DATE	DWN	APVD
J	-	SEE SHEET 1	-	-	-

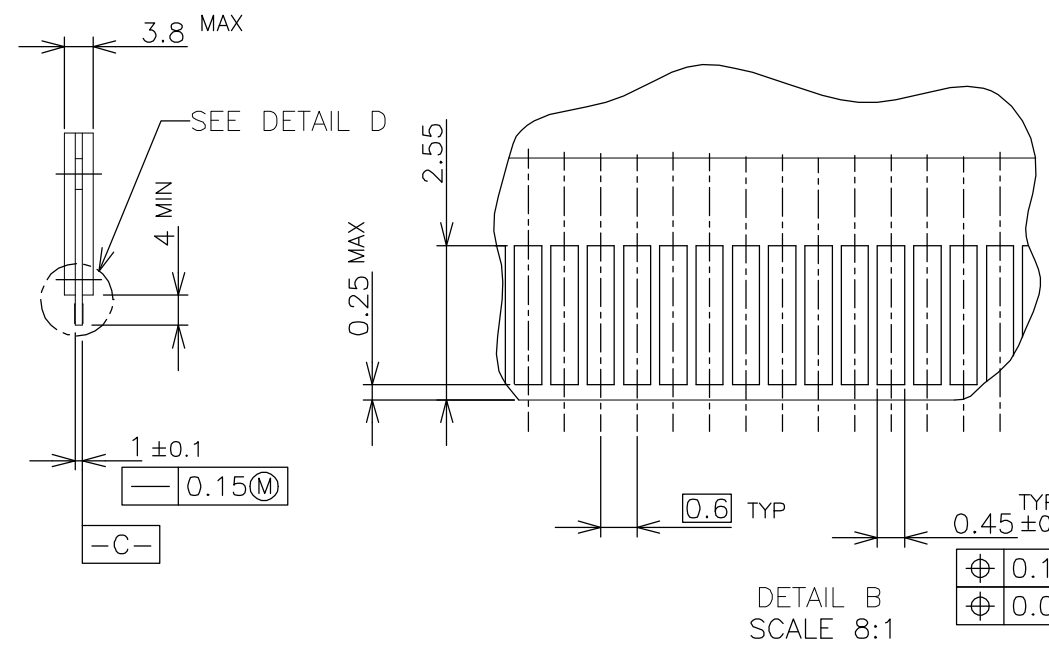
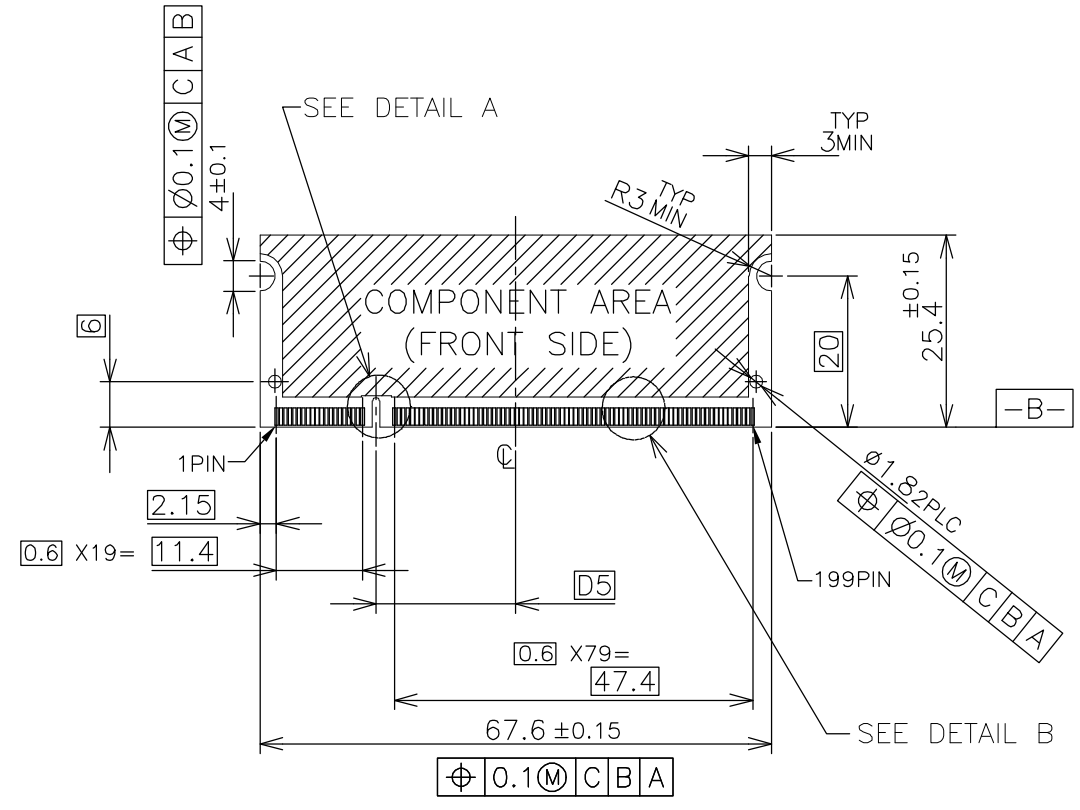

- (APPLIED TO SHEET 4)
1. TOLERANCES ON ALL DIMENSIONS ±0.15 UNLESS OTHERWISE SPECIFIED.
 2. P.C.BOARD THICKNESS APPLIES ACROSS TABS AND INCLUDES PLATING AND/OR METALIZATION.
 3. FINISH OF PAD : GOLD PLATING 0.00076 MIN. OVER Ni PLATING 0.002MIN.
- NO BURR.
- CHAMFER 0.25 MAX x 45° IF EXIST.

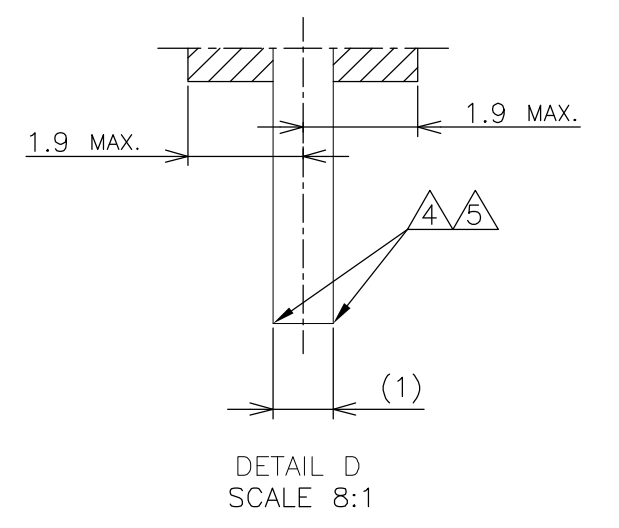
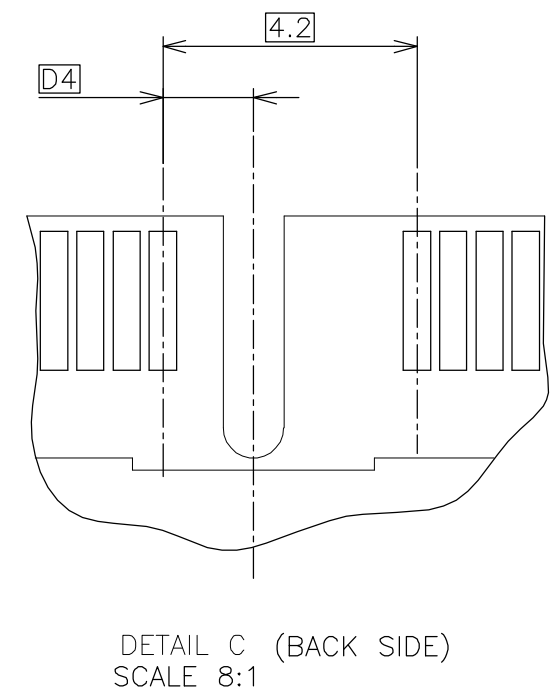
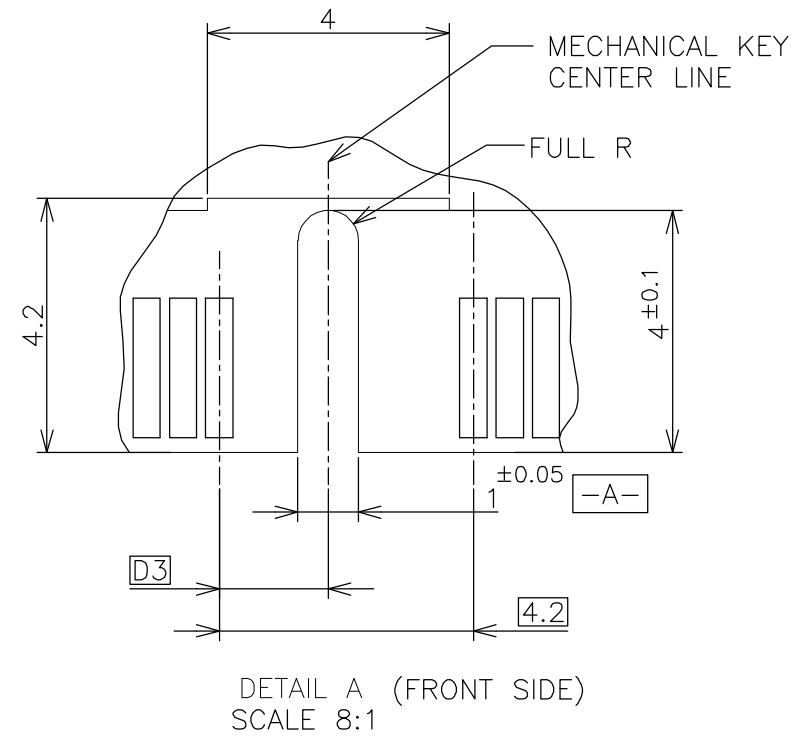
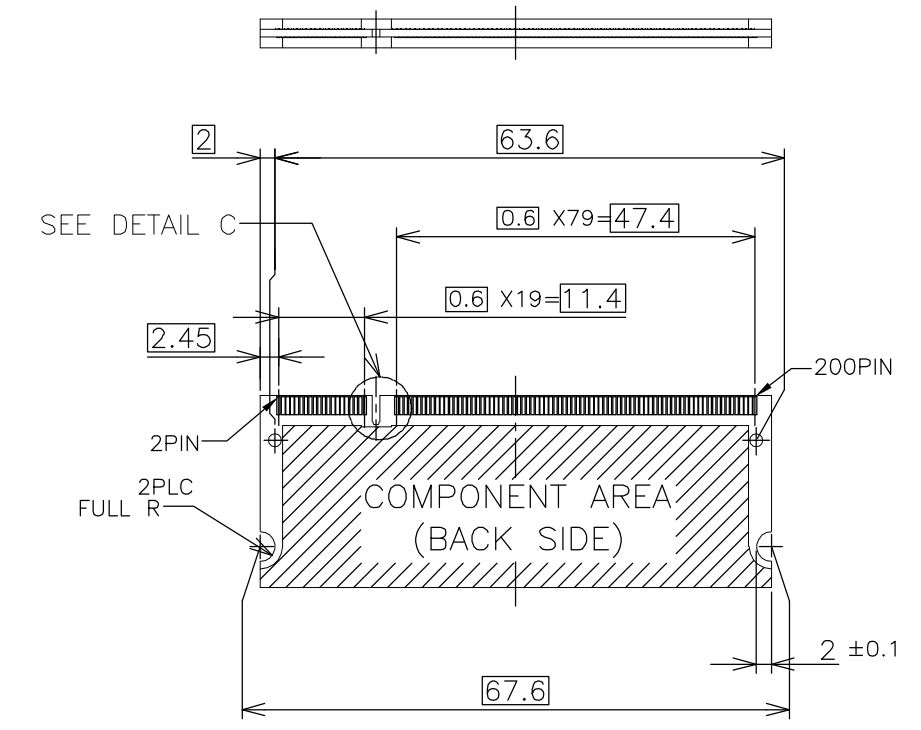

RECOMMENDED MATING P.C.B CONFIGURATION

1.8V (DDR2)	17.55	2.4	2.7
2.5V (DDR1)	18.45	1.5	1.8
POWER SUPPLY (TYPE)	D5	D4	D3

THIS DRAWING IS A CONTROLLED DOCUMENT.		DWN		Tyco Electronics AMP K.K. Kawasaki, Japan	
DIMENSIONS: MM		CHK			
TOLERANCES UNLESS OTHERWISE SPECIFIED:		APVD			
0 PLC ± 1 PLC ± 2 PLC ± 3 PLC ± 4 PLC ± ANGLES ± MATERIAL FINISH ±		NAME DDR1 & DDR2 SODIMM SOCKET 0.6mm PITCH 200POS 8mm HEIGHT STANDARD TYPE (LATCH DIRECT SOLDERING TYPE)			
MATERIAL		PRODUCT SPEC		SIZE	
		APPLICATION SPEC		CAGE CODE	
		WEIGHT		DRAWING NO	
		CUSTOMER DRAWING		RESTRICTED TO	
		SCALE 2:1		SHEET 4 OF 4	
				REV B	